

# Garduino: Sustainable Indoor Gardening Developed with Mobile Interface

Md. Anwar Hussen Wadud<sup>1</sup>, Anichur Rahman<sup>2,\*</sup>, Sadia Sazzad<sup>2</sup>, Dipanjali Kundu<sup>2</sup>, Muaz Rahman<sup>3</sup>,  
Airin Afroj Aishi<sup>4</sup>, Sm Nuruzzaman Nobel<sup>5</sup>, T M Amir Ul Haque Bhuiyan<sup>5</sup>, Zobayer Ahmed<sup>6,7</sup>

<sup>1</sup>*Department of CSE, Sunamgonj Science and Technology University, Sunamganj, Bangladesh*

<sup>2</sup>*Department of CSE, National Institute of Textile Engineering and Research (NITER),  
Constituent Institute of the University of Dhaka, Savar, Dhaka-1350, Bangladesh*

<sup>3</sup>*Department of EEE, National Institute of Textile Engineering and Research (NITER),  
Constituent Institute of the University of Dhaka, Savar, Dhaka-1350, Bangladesh*

<sup>4</sup>*Department of CIS, Daffodil International University, Dhaka, Bangladesh*

<sup>5</sup>*Department of CSE, Bangladesh University of Business and Technology, Dhaka, Bangladesh*

<sup>6</sup>*Department of Economics, Selcuk University, Turkey*

<sup>7</sup>*Department of Economics & Banking, International Islamic University Chittagong*

**Abstract** Smart gardening is more than just a laboratory experiment in today's world. The system enables water conservation and energy efficiency. Furthermore, it also improves plant health and increases production rate. Traditional methods involved a constant need to physically attend to the garden to water the plants. This task effectively gets easier with preinstalled water channels and mobile interfaces. The Internet of Things (IoT) can be a game-changer for the entire gardening experience. The challenges to implementing the system include understanding the plant's needs, and knowing how to operate the app interface. IoT can play a huge role in monitoring our garden remotely. This research proposes the idea of going a step ahead in terms of using automation for gardening experience. With the signature autopilot mode, the user app can control the automation, and the user does not need to turn on the water pump even from the app interface. Under certain set conditions, sensors will auto-detect garden status and start or stop machines based on pre-defined conditions. Through proper mathematical analysis and algorithmic approach, this work presents a great option for elderly people who find it difficult to water plants physically.

**Keywords** Smart Gardening, IoT, Smart Farming, Mobile Interface, Autopilot Feature, Wireless Networks, Model Apps.

**AMS 2010 subject classifications** 97P40, 97P60, 97R40

**DOI:** 10.19139/soic-2310-5070-2040

## 1. Introduction

The true potential of the Internet of Things (IoT) lies in creating interconnected devices that can be monitored and managed from a central point, a location that requires no human intervention[1]. A garden is one of the perfect platforms for this to happen. IoT systems can be effectively deployed to predict plant diseases in a garden and further comprehend the necessary factors to enhance plant growth accordingly. Implementing those technologies and practices can help improve efficiency, conserve resources, and ensure healthier and more productive gardens[2]. The IoT system also assists in monitoring the solar-based energy system [3]. The study in [4] has created an optimal environment, fostering extended and efficient growing seasons while guaranteeing lucrative harvests. They have developed an efficient system that features consistent monitoring of ambient elements, such as temperature,

\*Correspondence to: Anichur Rahman (Email: anis\_cse@niter.edu.bd). Department of CSE, National Institute of Textile Engineering and Research (NITER), Constituent Institute of the University of Dhaka, Savar, Dhaka-1350, Bangladesh.

dampness, and level of soil moisture, that ensures enhanced crop yield and promptly addresses any irregular conditions that arise.

Several works have detailed their strategies to reduce the human effort for gardening in an efficient manner. The techniques implemented yielded results that depicted the weather conditions of the surrounding environment and further alerted the end user regarding any abnormalities [5, 6]. The work presented in [5] did not highlight the effects of data due to poor networking facilities. The study further did not consider any ML algorithm to detect the purity level of water. The authors in [7] use greenhouse-based automated techniques and combine security features based on IoT. However, the study in [7], requires human intervention to effectively control the solenoid lock door through the Blynk platform. The work in [8] expands the challenges people face when maintaining gardens due to environmental conditions and lack of proper care. However, the work did not specify the facilities for recording historical data and overall maintenance features for popular plants. In [9], the potential of indoor gardening as a solution to the limitations of cultivating outdoor gardens is highlighted and the method proposes an IoT-based system to optimize indoor gardening, which provides access to comfortable gardening. The work in [10] allows users to regulate the enhancement of plants and other vegetation and forecast the possibility of rain. An application called Smart Garden, dedicated to growing and maintaining plants using traditional cultivation methods that involve soil, is proposed in [11]. Researchers developed a system to help its users gain remote access and maintain their indoor garden from a distant location in [12]. In paper [13], authors introduced a smart leveraging agricultural field data, implementing a machine learning model to provide improved utilization of water and optimized recommendations for soil conditioner use. This maximizes generation output while reducing supply utilization. In addition, it provides safety and energy harvesting technology [14]. Gardeners may precisely track the environment and soil conditions of their plants using the proposed method proposed in [15]. The authors designed a system to supervise and regulate the watering of plants in the garden by an automatic sprinkler system based on the damp condition of the soil. The Blynk app is used to provide users with a means of monitoring the garden conditions and controlling the watering process from their smartphone. In [16], researchers proposed the numerous advantages of incorporating autonomous smart garden features by using IoT technology for generating food in an efficient and secure manner. A system for a subsurface fibrous capillary irrigation system is proposed in [17]. The system shown in [18] depicts an overview of the IoT and Raspberry Pi technology and their application in various fields, such as transportation, agriculture, and medicine. Further, IoT-based systems also face some security concerns as the system is controlled over the networking system [19].

Considering all the work that has been studied and analyzed, we have discovered some problems remain unsolved. IoT undoubtedly plays a role when the garden is attended to [20]. However, issues remain when a garden is unattended and left on its own. For example, in [7], the modules operate from the phone. But in case the user forgets to turn on the water pump manually from the phone, there should be a rescue. Followed by a turn-on, the water pumped should also be turned off after reaching a certain soil moisture level. So, the problem will be absent in autopilot mode. Therefore, we became motivated to include something that makes a difference to automation.

Through our work, we have attempted to solve this problem using the autopilot mode. In the modern world, people often forget the plants in their garden or small balcony, and this app can automatically take care of their garden. When the autopilot mode is on, the system constantly checks for several values, like whether the temperature is suitable for the plants and well within the optimal range; if not, the heater will be turned on automatically without any human intervention. Next, determine whether the humidity of the air is appropriate for the plants; if not, the humidifier will be turned on automatically. In the event of reduced dampness level of the soil falls beyond a certain margin, the water pump should turn on automatically. Lastly, if there is an intrusion [21], the notification should be sent automatically. Thus, the garden can be monitored and controlled remotely 24/7, unattended. As long as the water channels are properly installed and autopilot mode is enabled, the “Garduino” can provide hassle-free gardening. By being able to control the irrigation module remotely, the elderly can stay at home longer, which reduces the effort required to take care of the plants. Fig. 1 shows a garden’s automatic irrigation and watering system. Overall, representation of the complete gardening system as a collection of interrelated subsystems. Where  $T$  is temperature control,  $H$  is humidity control,  $M$  is moisture levels, and  $P$  is

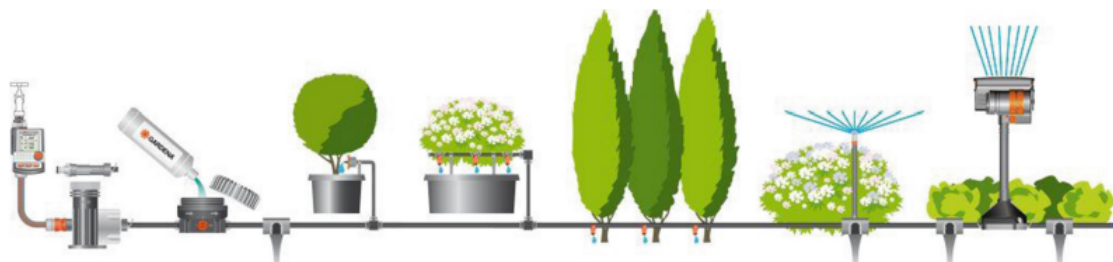

Figure 1. Gardena's automatic irrigation and watering system[9]

plant growth predictions. The main mathematical equation is as follows–

$$S = f(T, H, M, P) \quad (1)$$

Apart from this autopilot mode, the user will also have a manual mode, which will work according to the user's will. Garden chefs need to learn how to use the app interface, which is a simple and easy-to-use layout. Users hardly need any technical knowledge. One thing to watch out for in this system is to provide a constant power supply. Arduino UNO and the ESP2688 Wifi module must have a constant power supply. The contribution of the paper is as follows–

- This study proposes a significant autopilot mode with the necessary algorithms, which enables customers to conveniently manage their gardens from a distance. Unlike manual control, autopilot enables customers to easily take care of their plants even while away on vacation. The water pump is operated automatically based on soil moisture levels when a mobile interface is activated, dramatically enhancing the automation experience.
- This research highlights key mathematical analysis to offer uniqueness from the end-user perspective due to its ability to access the autopilot mode with added plant condition monitoring features, as long as the power is seamless. Further, the autopilot mode can be altered as required, and technical guidance can be sought to set new performance requirements.
- Finally, the authors present a unique feature that allows the system to gain knowledge of soil moisture and forms the basis of the science guiding plant watering. The model developed achieves continued water pumping until the soil moisture reaches the required level for the plant, preventing over-watering and providing the proper amount.

This paper is organized as follows– Section 2 presents the literature work. The motivation and proposal are covered in section 3. Most importantly, the part of the methodology is represented in section 4. Also, section 5 discusses the result analysis of this research. Finally, this article concludes in section 6.

## 2. Literature Reviews

This section discusses literature studies based on smart gardening systems that have been implemented conventionally and intelligently in various dimensions.

Anggara et al. discussed [7] their work and focused on the harvesting of medicinal plants in Parongpong District, West Bandung Regency, implementing the Smart Quranic Garden System prototype, an automated system based on IoT to solve the greenhouse effect problem. The system consists of three main elements: water, weather, and security. In another study, Ali et al. [8] designed a smart garden monitoring system using IoT and NodeMCU microcontrollers. This research offered an in-depth look at the integration of modern technology in agriculture, particularly in home gardens in large cities. It highlights the challenges that people will face when maintaining

gardens due to environmental conditions and lack of proper care using IoT along with NodeMCU microcontrollers and sensors to measure garden weather data and humidity levels incorporated with the Android mobile app. Similarly, [10] represented a smart gardening method assisted by a weather center that allows users to ensure the enhancement of plants and detect the possibility of rain. The method includes several sensors, including a pressure monitoring unit, a DHT11 sensory module, and a light meter sensor. The system also includes two actuators, a pumping mechanism for water regulation, and an LED, which can be controlled from a distant location or through the use of a device. Radu et al. [11] presented an application called Smart Garden, dedicated to growing and maintaining plants using traditional cultivation methods that involve soil. The application has two components: a mobile application for Android operating systems and a physical component called Smart Garden. In this process, a user generates an LAMP server to create an interface between the Smart Garden and the mobile app. Yaziz et al. [15] devised the development of a garden irrigation system that uses a Raspberry Pi 3 microcontroller and IoT technology [22]. The system is designed to control and monitor the watering of plants by automatically sprinkling water on the garden based on the soil moisture sensor readings. The Blynk app is used to provide users with a means of monitoring the garden conditions and controlling the watering process from their smartphone. The system is more effective than traditional irrigation methods, as it allows for efficient water usage and prevents over-watering of plants. However, leveraging IoT [23] presented a cost-effective mechanism for fire detection.

On the other hand, Olawepo et al. [16] proposed the numerous advantages of automated smart gardens utilizing IoT technology for enhanced food generation and security. The paper starts by introducing IoT technology and its potential to revolutionize various industries, including agriculture. It then describes the accessories necessary for the automated smart gardening features, which include microcontrollers and sensory modules connected through the internet. Further, a subsurface fiber capillary irrigation system's Kalman filter-proportional integral derivative (KF-PID) controller was designed and implemented by Abioye et al. [17]. The system performs below expectations because the depth at which water is needed was improperly calculated and modified. Between the fibrous capillary interface and the water's surface, the KF-PID controller mechanism is calibrated to regulate the appropriate amount of water at a certain depth. In other research, prior research in the field of IoT-based systems that are used for smart gardening and automation irrigation using soil sensors has been done. It was seen that the previous research as a significant gap, like a lack of solid user interfaces and extensive automation which is very crucial for the system. So, in this paper, a new solution was proposed where the technology of IoT and Blynk App were merged so that it can be used for efficient water control and plant care in home gardening and farms [24]. Sachin et al. [25] presented a unique way of combining cloud-based IoT technologies inside a VANET framework. This can improve efficiency as well as minimize energy usage, which can have a good impact on the sector. The study made by Norakmar et al. [10] stated that an IoT-based Smart Garden System with a Weather Station could provide practical benefits to researchers, farmers, and educational institutions. Scalability, sensor accuracy, user interface enhancements, new functionality, and the use of machine learning [26] for rain prediction and irrigation optimization can be improvised in future research. Another objective of the research article [27] depicts a process to create a categorization model for the classification of dehydrated food through a deep learning model. Authors from study [28] implemented a mechanism for categorizing high dimensional information using logistic regression method. The architecture integrates an IoT module with NodeMCU, soil conditioning sensors to automate water adjustments throughout the year based on palm age, and available weather conditions, and soil dampness levels. According to studies by [29], IoT-enabled solutions are important for remote monitoring and control of plant conditions. It typically focuses on optimizing irrigation and resource management to enhance plant growth and sustainability. In a recent study, it was seen that there is a growing interest in using technology that can smartly make it easier to garden. The main purpose of the study is to make gardening more efficient. This involves keeping an eye on the soil and how much water is needed for plants by using innovative algorithms [30]. Researchers in [31] proposed a smart agricultural system based on IoT with cloud computing. The work focused on the high yield of crops by utilizing the sensors to monitor the temperature and soil moisture level. The proposed system used the following equation to validate the production of the crop field.

$$y = t * s_m * area * 100 \quad (2)$$

Where  $t$  indicates temperature which should be within an optimal range of 180c to 250c,  $s_m$  stands for the soil moisture with an optimal value of 15 to 60%, and  $area$  indicates the area of crop field. An IoT-based indoor smart

Table 1. Overviews of the Existing Literature Works

Work with Year	Used Techniques	Implementation Area	Addressing Challenges	Outcomes
Aarhi et al. (2023) [2]	IoT	Backyard gardening	Additional sensors measuring soil parameters such as nutrients, organic matter and cation exchange capacity is needed.	The proposed system can be upgraded by adding features to accommodate irrigation response and garden fertigation. The work presented is reasonably satisfactory for a specific purpose.
Mohapatra et al. (2023) [34]	IoT, Arduino-based integrated smart watering system	Smart gardening system in cities	The work can be merged with deep learning and machine learning concepts to further its capabilities.	The proposed model achieved promising results in terms of reliability, scalability, timing and economics.
Netthikumarage et al. (2022) [35]	ML and IoT	Plant monitoring in urban areas	To integrate the interface in IOS or Windows lacks the addition of a plant disease detection	Though minor improvement is needed the work is exemplary in urban areas particularly when working with limited space.
Fauziah et al. (2022) [36]	IoT with LoRa	Smart gardening	The proposed model is suitable only for a limited range. Comparative analysis with relevant work is missing.	The presented work is marginally satisfactory and needs to be updated in terms of reliability and acceptance from user's perspective.
Ceccarini et al. (2021) [37]	IoT	Indoor home garden monitoring system	Integration of data visualization techniques, lacks engaging interaction with user, yet to develop a feedback system to develop	Still requires improvement on certain aspects of the system to assure user acceptance. The presented work is marginally satisfactory
Crisan et al. (2021) [38]	IoT	Multi-home automation with irrigation and other services	Lack of additional weather condition data including humidity level and others	Work is needed to integrate sensors that are capable of measuring numerous weather condition data. The work needs to add several features to gain more satisfactory user review.
Kurniawan et al. (2021) [39]	IoT	Indoor smart home gardening system	The data was slightly erroneous, improved interface can engage users on several platforms.	The work can be improved based on feedback from system operators. Increased user acceptance can be achieved by improving results and reliability issues.
Mohanty et al. (2021) [40]	IoT	Smart gardening	The system is unable to identify or categorize plant diseases. The system lacks feedback from the user end.	The work requires significant improvement in terms of user acceptability and detailed information
Campoverde et al. (2021) [41]	Reinforcement Learning, IoT sensors	Smart farm operation	The work requires a comparison with other research in similar areas, Lacks information regarding user interface	Although the technique does show improvement in terms of reduced water usage and energy consumption profiles, considerable development is needed to verify the technique used against other approaches.
Srithar et al. (2021) [42]	Deep learning, LSTM, GRU	Indoor plant monitoring system	The work presented needs comparative analysis with a similar approaches made in this research domain.	The work presents detailed results for the user. The interface used alert system operators with notification features using mobile apps.

gardening system is developed by authors in [32]. The study focused on the improvement of indoor air quality. The work considered a range of comfort index for a certain range of temperature and humidity, and the comfort index was calculated using the formula below.

$$\frac{1}{N} \sum_{N=1}^N \left[ 100 \left( \frac{|C_i^{opt} - C_i^{obs}|}{C_i^{max} - C_i^{min}} \right) \right] \quad (3)$$

Where  $C_i^{opt}$  = Median of comfort index,  $C_i^{obs}$  = Measuring value,  $C_i^{max}$  = Maximum of comfort index, and  $C_i^{minimum}$  = Minimum of comfort index. The work presented in [33] introduces a monitoring system using IoT. The work details an aquaponics system in which fish excretes are used as nutrients for plants. The amount of ammonia-nitrogen produced in the environment is estimated using the following equation.

$$G_{AN} = F * PC * k \quad (4)$$

Where  $G_{AN}$  is the generated ammonia-nitrogen in kg/day,  $PC$  stands for fraction of protein, and  $k$  is a constant amount of fish excretes per protein intake depending on the feeding rate.

### 2.1. Microprocessors Used

Authors in [16] used one of the most common kinds of micro-controllers, namely the NodeMCU. Anggara et al. [7] discussed their work that included the Repeat citations are used from previous sections. "Smart Quranic Garden System Using ATmega328 and ESP8266 Microcontrollers". Ali et al. [8] included the "IoT-based smart garden monitoring system using NodeMCU microcontroller". Bin et al. [10] in IoT-based Smart Garden with Weather Station system used the duo of NodeMCU and Arduino UNO. In [11], authors depicted an informatics solution for



a smart garden based on sensors. The work used a motherboard as their main component. UNCLEAR. In SIGMA: A Real-Time Soil and Environment Remote Monitoring for Indoor Garden Management [12] et al., the Raspberry PI 3 Model B+, which was employed as a multi-functional micro-controller, was used in [15]. The Raspberry Pi model 4 was utilized in [18]. There are numerous varieties of microcontrollers on the market. Depending on the needs of the project, one can be selected. Mathematically, we can present the following dynamic response equation of the system to environmental changes.

$$\frac{d\vec{y}}{dt} = A\vec{y} + B\vec{u} \tag{5}$$

Where  $\vec{y}$  represents the system states (temperature, humidity, moisture), and  $\vec{u}$  represents input controls (heating, watering).

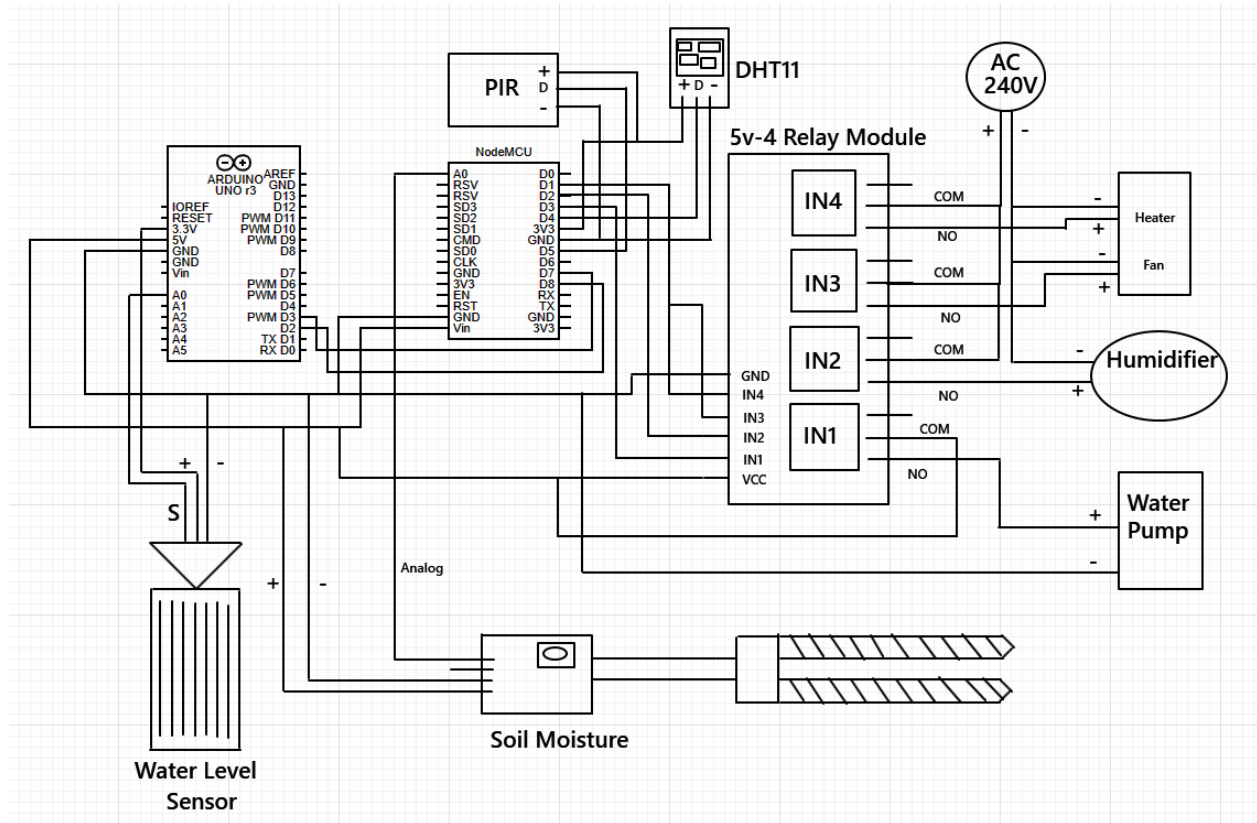

Figure 2. Proposed Diagram of the IoT Model used in “Garduino”

### 2.2. Application/Website for Remote Operation

[8, 11, 10], and [15] used Android Studio to develop individual mobile applications for their remote garden. Here the paper [10] used the BLYNK app as the mobile interface to remotely control the garden. [12] used the Sigma mobile application. Other options like Google Firebase, ThingSpeak, and RemoteXY are also great for use. These are SaaS services that have easy, comprehensive interfaces and are great for beginner users who are trying to develop smart gardens.

In summary, based on the above discussion, we showed that many researchers contributed a significant number of studies in the smart gardening areas. Table 1 presents the overview of the existing work with the challenges and outcomes associated. They used prominent platforms such as Arduino, Android Studio, and different sensors for

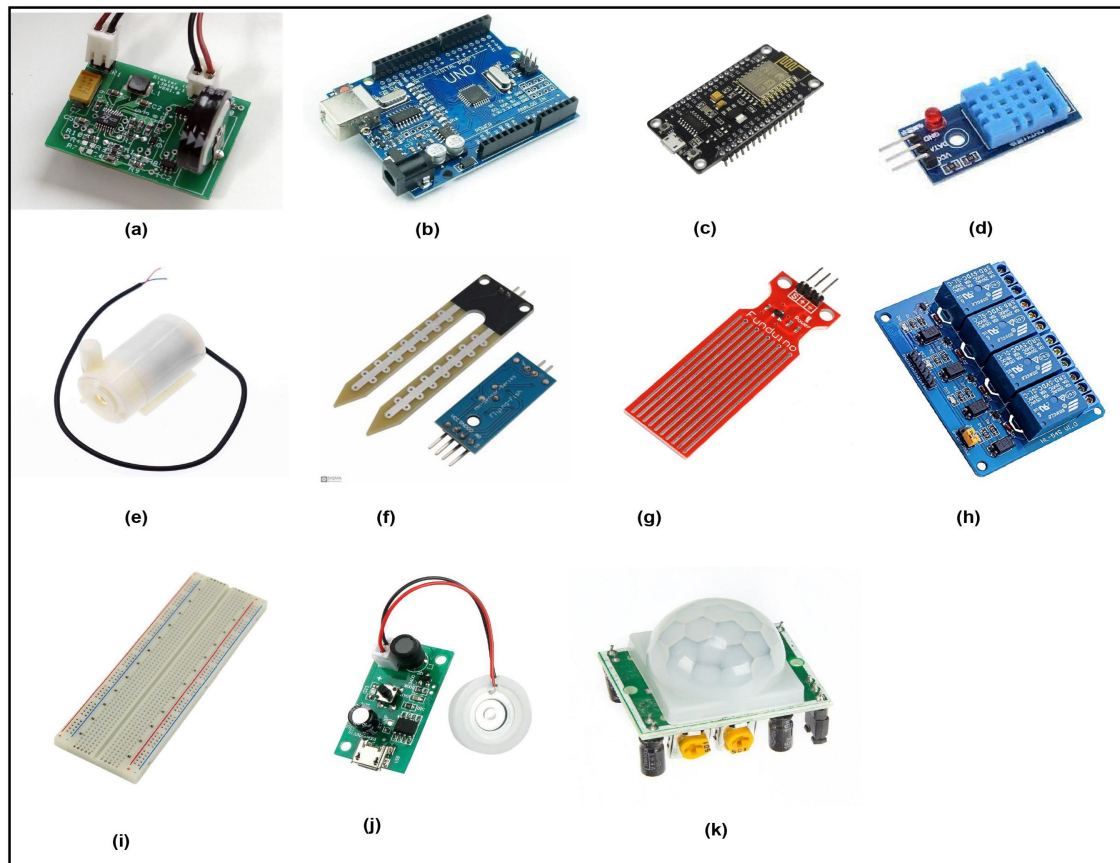

Figure 3. Hardware Components

the implementation. Motivated by them, we propose a smart indoor gardening system named “Garduino” through a mobile Interface.

### 3. Motivation and Proposal

#### 3.1. Motivation

Smartphone interfaces that are built to manually control a garden are a very well-known idea. This inspired us to leap one step further and introduce the autopilot mode. Having an autopilot function can be used even when you are not in the house or away from your house for a fairly long time. One more feature that we have introduced is water can be pumped from the water tank to the reservoir. So, there will be two submersible motors. One will be located in the main water tank of the house, and the other in the direct reservoir. If the water from the nearest reservoir runs out, then the second motor will be turned on to fill up the reservoir. Hence, the user will be free to fill up the reservoir frequently. Fig. 2 is our IoT model used in “Garduino”.

#### 3.2. Proposal

The presented system Incorporates quantitative models and optimization models with some mathematical relations.

**Quantitative Model:** Incorporate quantitative models that precisely represent the dynamics of the gardening approach. For instance, one can incorporate differential equations that describe the rate at which moisture in the soil changes, taking into account factors such as– evaporation, plant uptake, and irrigation [43].

$$\frac{dM}{dt} = I(t) - U(t) - E(t) \quad (6)$$

Where  $M$  is the moisture content,  $I(t)$  is the irrigation input,  $U(t)$  is the uptake by plants, and  $E(t)$  is the evaporation rate.

**Optimization Model:** To maximize growth expenses, develop optimization problems that determine the most effective scheduling for irrigation, nutrient application, or energy consumption [44].

$$\min_{x,y} Cx + Hy \quad (7)$$

$$\text{subject to: } \begin{aligned} Ax + By &\leq D, \\ Ex + Fy &\geq G, \end{aligned}$$

Where  $x$  and  $y$  are decision variables like water and nutrient levels, and  $C, H, A, B, E, F$  are coefficients derived from empirical data.

**Control and Information Model:** Devote control theory to the gardening system to preserve the intended state via corrective adjustments. One can choose to implement PID (Proportional-Integral-Derivative) controllers or more advanced control strategies such as Model Predictive Control (MPC) to optimize system responses [45].

$$u(t) = K_p e(t) + K_i \int_0^t e(\tau) d\tau + K_d \frac{d}{dt} e(t) \quad (8)$$

Where  $u(t)$  is the control action,  $e(t)$  is the system error, and  $K_p, K_i, K_d$  are the PID coefficients.

**Plant Growth Forecasting Model:** Devoting regression analysis to forecast plant blossoming using environmental data [46].

$$Growth_{rate} = \beta_0 + \beta_1 \cdot Temp + \beta_2 \cdot Humidity + \beta_3 \cdot Light + \beta_4 \cdot Moisture + \epsilon \quad (9)$$

Where  $Growth_{rate}$  is the dependent variable representing the rate of plant growth,  $\beta_0$  is the intercept of the model, indicating the baseline growth rate,  $\beta_1$  is the coefficient for temperature, showing its impact on growth,  $\beta_2$  is the coefficient for humidity, quantifying its effect on growth,  $\beta_3$  is the coefficient for light, reflecting its influence on plant growth,  $\beta_4$  is the coefficient for moisture in the soil, showing its importance for growth, and  $\epsilon$  is the error term, accounting for unexplained variability in growth. On the other hand, our proposed system consists of two main parts: the hardware configuration and the mobile user interface.

### 3.2.1. Hardware

- **Power Supply:** A power generating unit to regulate electric current from a source and provide one or more output connecting networks, providing supply to the essential loads. The circuitry for the power supply is shown in Fig. 3(a) [47].
- **Arduino UNO R3 SMD:** A microcontroller board based on the ATmega328 is called the Arduino Uno Rev3 SMD in Fig. 3(b)[47]. It consists of 6 input ports, a 16 MHz ceramic resonator (CSTCE16M0V53-R0), 14 digital input/output pins (of which 6 can be used as PWM outputs), a USB port, a power jack, an ICSP header, and a reset button.
- **ESP8266 NodeMCU:** As a flexible and affordable method of connecting items to the internet, the NodeMCU ESP8266 Fig. 3(c)[47] is a widely used development board in IoT applications. It has Wi-Fi and programming capability, which makes it easier to quickly prototype and deploy IoT solutions.



- DHT11 Digital Humidity and Temperature Sensor: A basic, affordable digital temperature and humidity sensor is the DHT11 in Fig. 3(d)[47]. It measures the humidity and temperature of the air around it using a thermistor and gives back a digital signal on the data pin (no analog input pins are required).
- YL-69 Soil Moisture Detection Sensor Fig. 3(e)[47]: To determine the dielectric permittivity of the surrounding medium, the soil moisture sensor measures capacitance. The water content of soil influences its dielectric permittivity. The soil's water content is determined by the voltage generated by the sensor, which produces a voltage proportionate to the soil's dielectric permittivity.
- 5v DC Submersible Mini Water Pump Fig. 3(f)[47]: By sucking water via its intake and releasing it through its exit, the water pump operates utilizing a water suction mechanism. The controlled water flow fountain and aquarium can both employ the water pump as an exhaust system. How to Use In the beginning, just attach a 3V or 5V DC supply to the red wire (+) and black wire (-).
- Water Level Sensor: Fig. 3(g)[47] is made up of sensor technology that can gauge the water level in any tank without human intervention. When there are tank leaks or overflows, the solution offers management useful insights that they may use to make informed and important decisions.
- 4 Channel 5V Relay Board: An easily accessible board that may be used to control high voltage, high current loads, such as motors, solenoid valves, lights, and AC loads, is the 4 Channel Relay Module, shown in Fig. 3(h)[47]. It is made to communicate with microcontrollers, including PIC, Arduino, and others. Screw terminals are used to bring out the relays' COM, NO, and NC terminals.
- Breadboard: A breadboard, sometimes referred to as a plug block, is used to construct short-term electrical circuits (Fig. 3(i)[47]). It is useful for designers since parts are easily replaceable and removable. One useful skill is being able to create a circuit, show how it operates, and then take the components and utilize them in another circuit.
- Heater: A convector or radiator is an example of a device that generates heat. Only when water is truly needed is heated by these heaters. When the car's heating is on, the inside will get heated quite fast. A convector or radiator is an example of a device that generates heat.
- 5V Humidifier Fig. 3(j)[47]: With the use of ultrasonic vibrations, the Mist Maker creates water vapor. The unit's ceramic discs vibrate to create tiny, micron-sized moisture droplets, which are then released into the air to elevate humidity levels to an ideal level.
- PIR sensor: An electronic sensor known as a passive infrared sensor (PIR sensor) keeps track of the infrared (IR) light that things in its field of vision emit. PIR-based motion detectors are where they are primarily used. In Fig. 3(k)[47], PIR sensors are extensively used in security alarms and automatic lighting systems.

*3.2.2. Mobile Interface* We will use Blynk Cloud as a service. Once the system is turned on, the sensor activates, and the sensor values are transmitted to Blynk Cloud via the ESP2688 WiFi module. If we connect to the mobile interface at this point, we will see the current status of the garden. We will be able to observe temperature, humidity, soil moisture, and water level. Also, if we think we should turn on the water pump, we can turn it on; or if the temperature of does not seem optimal for the plants, we can turn on the heater. The mobile interface has the following features:

**Temperature Reading:** Usually expressed in degrees Celsius ( $^{\circ}\text{C}$ ) or Fahrenheit ( $^{\circ}\text{F}$ ), a temperature reading is a measurement of the current temperature in a particular area or environment. It offers useful data for a number of uses, such as weather forecasting, observing the environment, and managing heating and cooling systems. Temperature readings assist us in understanding and adapting to temperature changes, which can affect our comfort, safety, and judgment.

**Humidity:** The term "humidity" describes the amount of moisture or water vapor in the air or another particular environment. It is a key element in weather, climate, and indoor comfort and is frequently stated as a percentage. Low humidity can result in dryness and associated health problems, while high humidity can make the air feel uncomfortable and clammy. Numerous applications, such as weather forecasting, agriculture, HVAC systems, and industrial operations [48], depend on the monitoring and control of humidity.

**Soil Moisture Content:** When stated as a percentage of the soil's total weight, soil moisture content gauges the amount of water present. It affects plant development, soil stability, and engineering considerations, which are all important in agriculture, environmental science, and building. It assists farmers in effective irrigation, aids in determining the health of the ecosystem, and assures adequate soil compaction in a building. For best results in these domains, precise monitoring and control are required. The authors in [49] used two sensors to detect the soil moisture level. The water content is measured by YL-69. Additionally, a temperature sensor and HC-SR04 ultrasonic sensor are utilized to detect the temperature and amount of water remaining in the container. Microcontroller Arduino UNO utilizes analog to digital converter from 0 to 1023 and measures the soil moisture content using the equation below:

$$\%s = 100 - \frac{ADC}{1023} * 100 \quad (10)$$

**Water Level Indication:** A container, reservoir, or system's current water level can be measured or shown as a water level indication. It is an important component of many applications, such as water management, environmental monitoring, and safety systems. Typically, water level indicators employ sensors or gauges to provide operators with real-time information on water levels, assisting them in making decisions and avoiding problems like overflows or shortages. Moreover, based on soil moisture and weather predictions, we can consider the optimization mathematical model for optimizing water usage [50].

$$Water_{usage} = \min \left( \sum_{i=1}^n (\text{Evapotranspiration}_i \times \text{Area}_i) \right) \quad (11)$$

Where  $Water_{usage}$  is the total water required, which we aim to minimize, min function aims to reduce the total water usage while ensuring sufficient irrigation based on evapotranspiration rates,  $\sum_{i=1}^n$  sums the water needs over all  $n$  distinct areas or zones in the system,  $Area_i$  refers to the size of the  $i$ -th area, influencing the total water calculation for that zone.

**Intrusion Status:** The security situation relating to unauthorized access is called intrusion status [51]. It's essential for security systems and can be considered "secured" when there are no breaches or "breached" when unauthorized entry is discovered. Potential security threats are addressed using this knowledge.

**Humidifier controls:** A humidifier is a device used to increase the moisture content of the air. Humidifier controls are the mechanisms or settings that enable users to control and manage the operation of a humidifier. Typical examples of these controls are:

- **Power/On-Off:** The fundamental switch for starting or stopping the humidifier.
- **Humidity Level Setting:** Many humidifiers allow customers to choose the preferred humidity level, and the appliance will attempt to keep that level in the space.
- **Fan Speed:** Some humidifiers offer a fan speed adjustment to regulate how quickly moisture disperses.
- **Timer:** Users can set when the humidifier should run using the timer function, which can be helpful for energy conservation or maintaining humidity levels at specified periods.
- **Mist Output:** Controls to alter the mist output may be found on evaporative or ultrasonic humidifiers.
- **Water Tank Capacity:** Displaying or monitoring the water level in the humidifier's tank using indicators or controls.
- **Safety Features:** Controls for safety features, including automatic shut-off when the water tank is empty or when the optimum humidity level is attained.

Utilizing these controls, customers can modify the humidification procedure to meet their comfort and environmental requirements, assuring ideal moisture levels inside of buildings.

**Heater Controls:** The mechanisms or options that allow users to control and manage the operation of a heating device, such as a space heater or central heating system, are known as heater controls. These restrictions often consist of:

- **Temperature Control:** Users can set the desired temperature to keep a space at a certain level. While some heaters have simple low-to-high heat settings, others include precise temperature controls.
- **Power/On-Off:** The primary control to start or stop the heater is Power/On-Off.
- **Fan speed:** Users of forced-air heaters may be able to alter how quickly the heat is spread by adjusting the fan speed.
- **Selecting a mode:** Some heaters offer a variety of settings, including “fan-only” for circulation without heating and “eco mode” for an operation that uses less energy.
- **Timer:** The ability to set when the heater should work enables consumers to conserve energy while maintaining comfort.
- **Thermostat:** Many heaters have thermostats built into them that regulate the temperature by turning the heater on and off as necessary.
- **Controls that assure safe operation** include safety features including tip-over protection, overheat protection, and kid locks.
- Some heaters are equipped with remote controls that make adjustments easy from a distance.

These settings enable customers to personalize their heating experience, guaranteeing comfort and energy efficiency while upholding a secure and comfortable indoor climate.

**Water pump controls:** Water pump controls are systems or configurations that let users control and oversee the operation of a water pump, a device used to transport water from one place to another. These controls can differ based on the type of water pump and the intended use, but they commonly consist of the following:

- **The basic control** to start or stop the water pump’s functioning is the on/off switch.
- **Controls to Change Water Pressure or Flow Rate:** Some pumps, particularly those used in water delivery systems, may incorporate controls to Change Water Pressure or Flow Rate.
- **Timers:** Timers allow you to program when the water pump should turn on and off, which helps run irrigation systems or restrict water use at certain times.
- **Automatic Pressure Switch:** Using this control, the pump can be started and stopped automatically depending on the water pressure. Water pumps and some home water delivery systems frequently use them.
- **Manual Overrides:** Some pumps contain manual override switches or controls that allow the pump to be manually operated in addition to automatic settings.
- **Variable speed controls** allow for precise adjustment of the pump’s speed and output to match needs, enhancing energy efficiency in some applications like HVAC systems or industrial processes.
- **Remote Control:** In some pump systems, remote controls or monitoring systems can be utilized to remotely control and keep an eye on the pump.
- **Controls for safety measures**, such as overload protection or a low water cutoff, to prevent the pump from being harmed.

By enabling users to adjust water distribution, pressure, and usage, these controls enable water pump systems to be flexible and adaptable to a range of requirements, from domestic water delivery to industrial processes and agriculture.

**PIR Sensor Controls:** Controls and settings for PIR (passive infrared) motion sensors are used to regulate their behavior and mode of operation. Using variations in infrared radiation, PIR sensors are frequently employed in security systems, lighting automation, and other applications to detect motion or the presence of a person or item. These are a few examples of standard PIR sensor controls:

- **Sensitivity Adjustment:** Users may adjust the PIR sensor’s sensitivity level to control how quickly it reacts to motion. In contrast to lower settings, which require more significant motion to activate the sensor, higher settings may detect even small motions.
- **Time Delay Setting:** How long the sensor is “on” or active after detecting motion is controlled by the time delay setting. The delay can be configured by users to keep lights or other devices on for a predetermined amount of time, often between a few seconds and several minutes.

- **Trigger Mode:** Some PIR sensors include a variety of trigger modes, including “occupancy” mode (the sensor stays on as long as it senses motion) and “vacancy” mode (the sensor goes off after a predetermined amount of inactivity).
- **Controlling light sensitivity:** PIR sensors sometimes cooperate with ambient light levels. Customers can modify the sensor’s sensitivity to ambient light to control whether it should turn on depending on the ambient lighting.
- **Test Mode:** By activating the sensor in this mode without any motion, users can test the sensor’s operation. It makes installing and troubleshooting easier.
- **Override or Bypass:** To temporarily disable or bypass the sensor’s operation, some PIR sensors may offer human override settings. This feature is handy when continuous lighting is required regardless of motion.
- **Reset or calibration:** Calibration controls help establish the starting state or “baseline” of the sensor, ensuring precise motion detection.
- **Adjusting the range:** Depending on the sensor, users may be able to narrow the detection range to a smaller region or a greater distance.

With the help of these controls, users can modify the way PIR sensors behave to meet the particular needs of their applications, whether they are for automated or automated lighting, security, or other purposes. Furthermore, models the system’s dynamic reaction to environmental changes. Where  $\vec{y}$  represents the system states (temperature, humidity, moisture), and  $\vec{u}$  represents input controls (heating, watering).

$$\frac{d\vec{y}}{dt} = A\vec{y} + B\vec{u} \quad (12)$$

## 4. Proposed Methodology for Sustainable Gardening System

### 4.1. Hardware Setup

1. The Arduino serves two purposes. The first is to enable NodeMCU through the Vin pin. The second is to collect data from the water level sensor. This data is transferred to the NodeMCU via the serial pins D3 (Arduino TX) and D7 (NodeMCU RX).
2. The water level sensor is powered by the 5V from Arduino. Arduino’s A0 analog pin is connected to the water level sensor’s analog pin.
3. The YL-69 soil moisture sensor uses a 5v power supply. The analog pin of the soil moisture sensor is connected to the analog pin A0 of NodeMCU.
4. The PIR sensor is powered with 3.3V from NodeMCU. The digital pin of the PIR sensor is connected to the digital pin (D5) of the NodeMCU.
5. DHT11 temperature and humidity sensor is powered by 3.3V from NodeMCU. The digital pin of DHT11 is connected to the digital pin D4 of NodeMCU.
6. The 5v 4 relay module has 4 input pins, 1 VCC, and 1 ground pin. The relay module is supplied with 5v via the Arduino. The two input pins of the relay are connected to the digital pins D8 and D2 of the NodeMCU, respectively. The remaining two input pins of the relay share the same NodeMCU data pin, which is D1.
7. The air heater is controlled by the relay module via pin-IN4 and IN3 and is powered by AC (240v).
8. The humidifier is controlled by the relay module via pin-IN2. The humidifier is powered by DC (5v) and connected to AC (240v), and the AC 240V is converted to DC 5v by a USB charger.
9. The water pump is controlled by the relay module via pin-IN1. The water pump is supplied with direct current (5V) from Arduino.

### 4.2. Cloud Connectivity

For the cloud connection, we have used Blynk as a remote server to process sensor data and control various functions of “Garduino”. Blynk works with NodeMCU using NodeMCU’s built-in Wi-Fi module to communicate

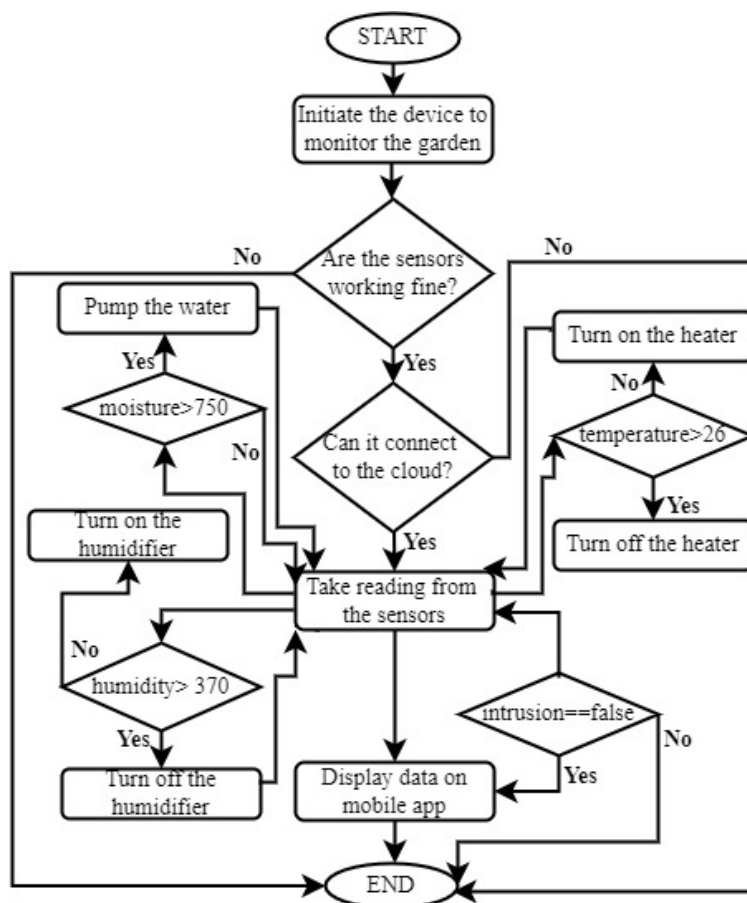

Figure 4. Workflow diagram of our proposed IoT-based “Garduino” system

with the Blynk server. To establish a remote connection to the Blynk server, we need the Blynk authentication key and the credentials of the local Wi-Fi router. The sensors send data to the virtual pins of the Blynk server via NodeMCU. Virtual pins are used to communicate with NodeMCU hardware. The Blynk application can control and monitor the NodeMCU hardware by sending and receiving data through the virtual pins defined in the sketch.

### 4.3. Algorithmic Analysis

We develop and detail algorithms that automate decisions based on sensor data. Further, we employ pseudocode to describe algorithms that handle data processing, anomaly detection, or system reconfiguration in response to environmental changes.

**4.3.1. Working Procedure of the System Mode with a Proposed Algorithm:** The process by which the system operates is shown in Fig. 4. The sensors activate when the system is turned on, and the Arduino then determines whether or not the sensors are functioning properly. If the result is no, the system terminates, and if the result is positive, it checks the internet connection and connects to the cloud of Blynk. If the connection setup is not possible, then the system procedure ends, and otherwise, take readings from the sensors. The sensors are soil moisture sensors, temperature sensors, and humidifiers. If the soil is dry, then the pump water process is initiated, and while the soil is moist enough, the pump remains idle. This is done by comparing it with the threshold value. The Algorithm of this process is presented in Algorithm 1. While the temperature is high, then the heater is idle; otherwise, it is turned on. On the other, when the sensing output to the humidifier is high, the humidifier is turned



---

**Algorithm 1** Adaptive Watering Algorithm

---

**Require:** Soil moisture level  $S$ , Threshold  $T$ , Device functionality status  $D_f$ , Cloud Sensor Connection Status  $C_s$ **Ensure:** Water pump status  $W$ 

```

while ( $D_f == \text{True} \ \&\& \ C_s == \text{True}$ ) do
  if  $S < T$  then
     $W \leftarrow \text{ON}$ 
  else
     $W \leftarrow \text{OFF}$ 
  end if
end while
if ( $D_f == \text{False} \ \&\& \ C_s == \text{False}$ ) then
  Process End and Report Error
end if

```

---



---

**Algorithm 2** Proposed Algorithm for Monitoring the Gardening System

---

**Require:** Values of moisture, temperature, intrusion, humidity sensors**Ensure:** InitiateTheDevice() $=1$ 

```

1: DeviceFunctionality() $=\text{True}$ 
2: CloudSensorConnection() $=\text{True}$ 
3: if DeviceFunctionality() and CloudSensorConnection() then
4:   while (moisture  $> 750$ ) do
5:     Pump the water
6:     Update moisture
7:   end while
8:   while (temperature  $> 26$ ) do
9:     Turn off the heater
10:    Update temperature
11:  end while
12:  while (intrusion  $== \text{False}$ ) do
13:    Display data on the mobile app
14:    Update intrusion
15:  end while
16:  while (humidity  $> 370$ ) do
17:    Turn off the humidifier
18:    Update humidity
19:  end while
20: else
21:   Report Error
22: end if

```

---

off and, if not, then turned on. Again, when there is no third-party involvement, the PIR sensor will not send any signal and will remain idle. But in case any intrusion is detected the PIR sensor will send a necessary signal back to the controlling part. According to this working procedure, the proposed algorithm is described is Algorithm 2.

**4.4. Code Segment Analysis**

We have used the Arduino IDE to flash the firmware in both the Arduino UNO board and ESP8266 (NodeMCU). We have programmed the Arduino UNO board and ESP8266 with the necessary code to interact with the Garden module. Once programmed, we will be able to activate and control the various functions of the garden. Our

prime objective is to analyze the current garden state and act in accordance. Now once the system is powered up, “Garduino” will appear to be online in our Blynk interface. At this point, our garden will be fully functional. The signature feature of “Garduino” is it can operate on its own without any human intervention, it is called the autopilot mode and it can be enabled or disabled at any time through the Blynk app. Below is the code snippet of Garduino’s signature function in Fig. 5.

```
void autoPilotE(int value)
{
  if(value == 1)
  {
    autoPilot = 1;
    Blynk.virtualWrite(V14, "Engaged!");
  }
  else
  {
    autoPilot = 0;
    Blynk.virtualWrite(V14, "Disengaged!");
  }
}
```

Figure 5. Code segment for Autopilot feature

#### 4.5. Scalability of the Proposed System

Fundamentally modular systems allow users to operate in small regions and expand by adding more components conveniently as needed. To form a smart garden, user can choose suitable features and plants, growth mediums, and environmental controls based on their preferences and space availability. The proposed model is sustainable and suitable for a larger approach, along with commercial gardening. As the system has a user-friendly context and mobile monitoring concept with the help of IoT and automation, the larger farm owners can establish a modular setup for commercial purposes. Cloud integration, analytics, and insights are also included to improve data management for sustainable gardening. Although some additional cost and complexity may arise for the larger system implementation, the proposed model can improve the irrigation system with the help of an IoT-based automated monitoring system.

#### 4.6. Security Concerns

Smart IoT-based gardening systems may offer more convenient and efficient outcomes, but they also come with some potential security concerns. Smart gardening devices often collect data and activities about the home environment where the garden is installed. Thus, data privacy may be hampered. If any device has vulnerabilities, it may create an unavoidable network-blocking scenario. For that reason, anyone can enter the system through hacking. As the home network is connected to Wi-fi, weak passwords and outdated encryption might compromise the entire communication system. Addressing such matters, the proposed model used end-to-end encryption for data security. For that reason, when the installed device broadcasts, the message is encrypted, and vice versa. Encryption for communication channels is also implemented where the device is connected to the cloud.

Furthermore, verifying the user identity to prevent unauthorized access is incorporated with the proposed model. By implementing strong passwords and multi-factor authentication, the proposed model was established as a secure model for indoor users as well as for vast commercial purposes. Role-Based Access Control (RBAC), maintaining activity Logs, Intrusion Detection Systems (IDS), and regular audits of the system's software along with the physical components may bring the sustainability of the system.

## 5. Result and Discussion

A smart garden, often known as a “Garduino”, is a technologically enhanced garden or plant care system created to maximize plant growth and health while minimizing human work. The physical layout of this system is shown in Fig. 6.



Figure 6. Physical layout of “Garduino” System

### 5.1. Experimental Setup

Before implementing our proposed model for “Garduino”, we performed the necessary configuration because this proposed system implementation has two modules: one is a hardware module, and another is a software module. For the hardware module, we need different devices according to our proposed system and need to connect accurately so that the overall system works without any failure. These device connection details are already mentioned in section 4.1 of the proposed methodology. The detailed components’ names with specific versions are mentioned in Table 2. For the software module, we have to configure the system through appropriate programming that can ensure the overall working process of the proposed system has been done without any inconsistency. We use Arduino IDE for the compiler, where we write the necessary programming for the proposed system. To control the NodeMCU microcontroller through this Arduino IDE, we have to configure some necessary software components that will help to control the microcontroller according to the required instructions and which is provided by several sensors.

First, we have to download and attach one necessary library ESP8266Wifimaster as zip file to the following section of the Arduino IDE (Sketch>Include Library > Add .ZIP library...). Now we have to download library ‘arduinojson’ through the following section of the Arduino IDE (Sketch > Include Library > Manage libraries). In this section, we have to type ‘Arduinjson’ and select a version. After that, we have to download board manager ESP8266 through the following section of the Arduino IDE (Tools > Board > Boards Manager...). Here, we have

Table 2. Specification detailed of the Hardware and Software Modules

Component Type	Component Name	Component version
Software (OS)	Windows	10
Software (Compiler)	Arduino IDE	1.8.19
Software(library for ESP8266 board)	ESP8266	2.4.1
Software(library for ESP8266Wifi module)	ESP8266 WifiMaster	1.0.0
Software(library for ESP8266 board)	Arduinojson	5.13.1
Software(library for sensor)	DHT11 sensor	1.4.3
Software(library for Blynk IoT Cloud)	Blynk	1.0.1
Hardware (Microcontroller)	Arduino	UNO
Hardware (Microcontroller)	NodeMCU (ESP8266 Module)	Lolin NodeMCU V3
Hardware (sensor)	DHT	11
Hardware (sensor)	Water level detection sensor	-
Hardware (sensor)	Soil Moisture detection sensor	YL-69
Hardware (sensor)	PIR Motion sensor	HC-SR501
Hardware (sensor)	5v Humidifier	HSM-20G
Hardware (water pump)	5v DC Submersible Mini Water Pump	-
Hardware (Relay)	4 channel Relay module	-
Hardware (breadboard)	Solderless Breadboard (large size)	-

to type ESP8266 and select a version. Then, we have to download another library to control the DHT11 sensor through the following section of the Arduino IDE (Sketch > Include Library > Manage libraries). Here, we have to type 'dht sensor' and select a version of the library. Now, to communicate with the Blynk IoT cloud, we have to download and install a library, and it is also performed in a similar way from the Arduino IDE (Sketch > Include Library > Manage libraries). Here, we have to type 'blynk' and select a version of the library. Also, we have to create an account for the Blynk IoT cloud server and configure all necessary processes to control different sensor devices according to the proposed systems. During the configuration process of the Blynk IoT cloud, a template ID and device name will be created, which we have to use in programming the Arduino IDE. Through these template IDs and device names, the data can be read and written from NodeMCU to the Blynk IoT cloud server. When we download all the necessary libraries, then, we have to write code in Arduino IDE. In Arduino IDE there are two default methods are mentioned. One is setup(), and another is loop(). Here, in the setup() method, we write the necessary codes to initialize device connections through different built-in methods, and we also have to mention specific pin numbers where the different devices, like sensors and other devices, are connected. In the loop() method, we have to write the main execution process using a detailed proposed algorithm through programming.

Furthermore, our proposed system implementation is written in C/C++ coding format. After finishing the coding with C/C++ programming and before running, we have to select the NodeMCU board through the following section of the Arduino IDE (Tools > Board > ESP8266 Modules > NodeMCU 1.0 (ESP 12-E Module)). Now, we have to compile the code through the 'Verify' section of the Arduino IDE to check if there are any syntax errors or not. If there is no syntax error, then we have to write the code in the primary memory (ROM) of the NodeMCU microcontroller through the 'Upload' section of the Arduino IDE. We run this proposed system on a Windows 10 operating system with a Corei7 CPU and an 8.0GB RAM personal computer device. So, if anyone wants to run this system with another operating system like Linux or MAC, then the configuration process will be a little bit different. The detailed software components' name with specific versions is mentioned in Table 2.

## 5.2. PIR Sensor

With the help of the PIR sensor, we will be able to detect movement in the garden when we are away. When we want to enter the garden we will turn off the PIR sensor from our mobile interface. Fig. 7 shows the status of a certain point. When we will exit the garden we will turn on the PIR sensor from our phone. Any intrusion will also

send Blynk notifications and email notifications. In addition to it, statistical analysis of sensor data [52] to predict future environmental conditions.

$$X_t = \alpha X_{t-1} + \beta T_{t-1} + \gamma M_{t-1} + \delta H_{t-1} + \varepsilon_t \tag{13}$$



Figure 7. PIR sensor status

### 5.3. Humidifier

The humidifier is here to control the water content of the air. Whenever the air humidity is below 60 percent, the autopilot will turn on the humidifier; apart from that, the humidifier can be turned on and off whenever needed, which is shown in Fig. 8.

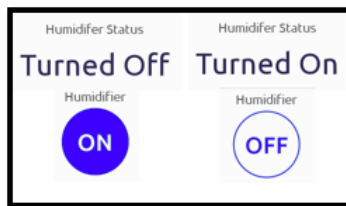

Figure 8. Humidifer switch status

### 5.4. Heater

The optimal temperature for plants is 26 degrees Celcius. If the temperature drops below 26 the heater will be turned on. Once the temperature exceeds 26 degrees, the heater will automatically turn off.

### 5.5. Water Level Sensor

In Fig. 9, shows the water level statement status. The water level sensor provides analog readings depending on the water level in the reservoir. The reservoir has five distinct statuses: empty, low, half, nearly full, and full, and Fig. 10 presents water level analog status.

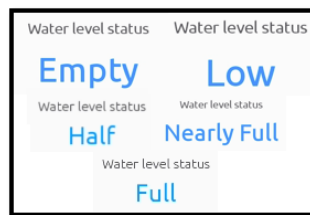

Figure 9. Water Level statement status



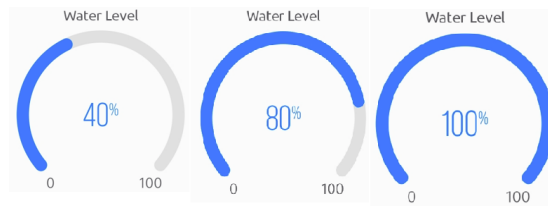

Figure 10. Water Level Analogue status

### 5.6. Soil Moisture Sensor

In Fig. 11, the soil moisture sensor also provides an analog reading depending on the water content of the soil. There are three distinct statuses: critical, moderate, and good. Fig. 12 shows soil moisture analog status. The work in [53] delineates the utilization of a grove soil moisture sensor. The proposed system developed by the authors utilizes a data acquisition board that samples the input signals from the sensor to obtain the ADC readings. The ADC readings are then converted into a voltage  $v$  reading using the equation below:

$$v = 2.5 * ADC_r / 4096 \quad (14)$$



Figure 11. Soil Moisture status

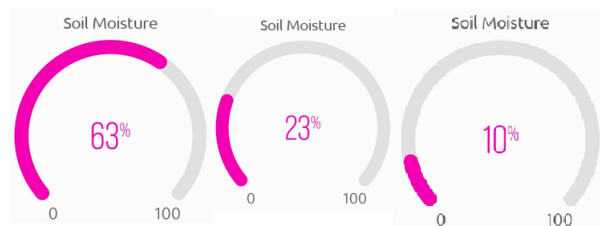

Figure 12. Soil Moisture Analogue status

### 5.7. DHT11 Temperature

The DHT11 temperature measures the temperature of the air; the optimal temperature for plants is 26 degrees Celsius. This temperature is important for the record because if the autopilot mode is activated, the heater will turn on at this level. Fig. 13 shows different analog readings of temperature.

### 5.8. Water Usage Reduction

For comparative analysis, we have taken the data from September 2023 to February 2024. As the plant's optimal temperature is maintained at around 26 degrees with the help of the sensor in the system, for this reason, the water requirement is almost the same for each month. However, without system usage, the water requirement varies and, at the same time, is higher than the system water requirement. For example, in September 2023, the average temperature gained was 29 degrees centigrade, and for this reading, the water required for the whole month is about 80 liters, but at the same time, the automated system required only 56 liters of water for that month by saving about 30 percentage of water as shown in Fig. 15.

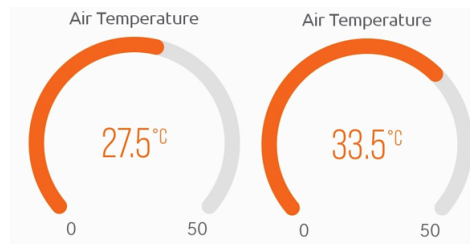

Figure 13. Different Analogue Readings Temperature

### 5.9. Mobile Application

We used the Blynk cloud service to monitor the project using a mobile application. The WiFi module connects the Arduino UNO to the Blynk Cloud. It will display the status of the garden in real-time. It can monitor, control, and adjust garden settings remotely from our smartphone or computer. Data from sensors is stored in the cloud. Our smartphone app interface retrieves and displays updated data in real-time. The overview of the mobile application interface is shown in Fig. 14.

### 5.10. Comparison with Existing System

The proposed system introduces a unique automated gardening experience for users and is considerably advantageous as opposed to similar technology used in this realm. The unique feature of the proposed system is highlighted in Table. 3 outlining the key advantages as compared to other automated indoor gardening strategies. In Table. 3, we compare our proposed system with current systems based on a range of criteria or elements. Following our description, it seems that we are indicating, about current systems, whether a particular component or parameter is present in our system (marked as “yes”) or not (marked as “no”). The work presented in [54], [29] and our existing system utilized the node MCU. DHT11 is utilized in our suggested system as well as [9], [55]. The Galileo board is only utilized by [56]. The 5V humidifier exists in [9], [11], and our suggested system. A PIR sensor is present only in the setup of our suggested system. We appear to have successfully compared how these elements or parameters are present in other systems. Researchers in [57] used IoT, ML, and cloud computing to develop a smart agricultural system. The authors implemented the exponential moving average model for predicting weather conditions. The proposed model requires less computational time as compared to the regression model and uses its past data to improve its accuracy. The model can be described using the equation below:

$$S_t = \alpha * Y_t + (\alpha - 1) * S_{t-1} \quad (15)$$

Where  $S_t$  defines a series  $S$  of local mean value at time  $t$  and  $\alpha$  indicates the smoothing constant. The work presented in [42] presents information about the plant condition using a cloud platform through the use of deep learning algorithms. Long short-term memory deep learning model is used to predict values from the pre-processed data collected from several sensors. The structure for the long short term memory equations is given by the equations shown below–

$$it = Alpha(wixt + Uimt - 1 + bi)f_t = (wsxt + Usmt - 1 + bs)c_t = c_t - 1 * ft + st * imt = st * ot \quad (16)$$

Another work [58] introduces IoT based low-cost system for irrigation purpose. The proposed model utilizes neural network (NN) and effectively identifies the need of water by considering plant and soil conditions. The water requirements for crops in this proposed model is given by,

$$Omega_{\bar{e}} = \varphi(P_g, A_t, A_h, S_m, ET_{\bar{e}}) \quad (17)$$

$P_g$  indicates plant growth stage,  $A_t$  represents ambient temperature,  $A_h$  denotes ambient humidity and  $S_m$  indicates soil moisture. In the above equation,  $ET_{\bar{e}}$  represents crop evapotranspiration which can be modeled using

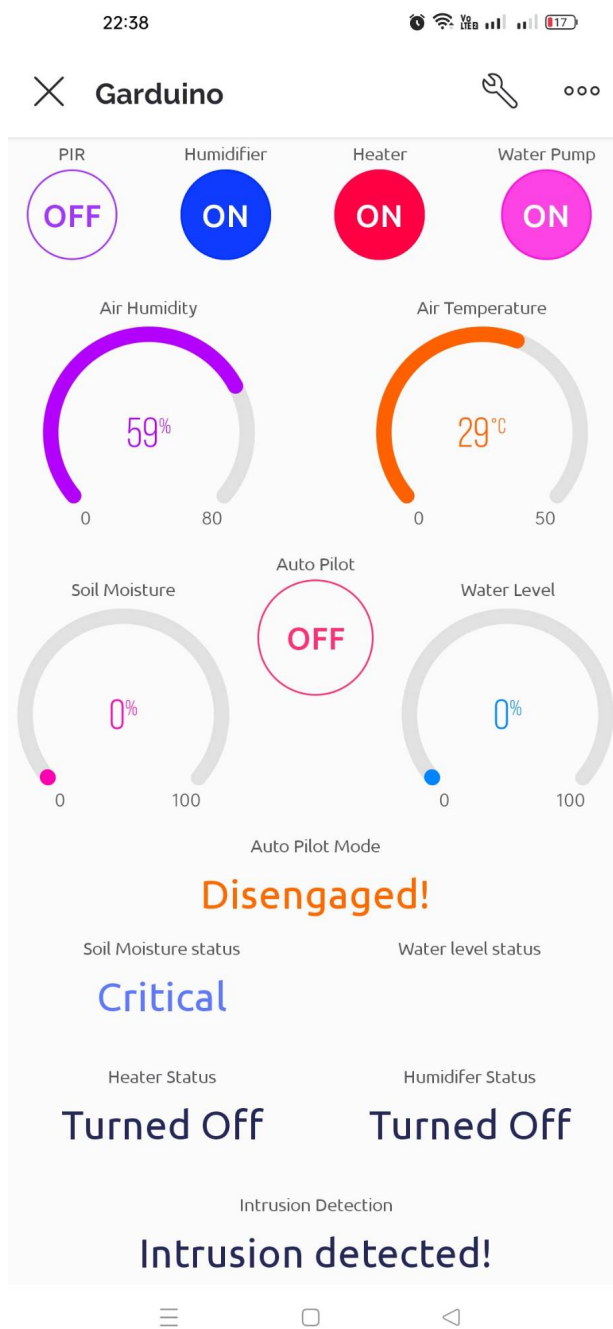

Figure 14. Mobile Application Interface of “Garduino” work

the following equation,

$$ET_{\bar{c}} = k_{\bar{c}} * ET_0 \tag{18}$$

Where,  $k_{\bar{c}}$  is crop coefficient and  $ET_0$  is reference evapotranspiration. The authors in [59] presented a linear multiple regression algorithm in the domain of smart agriculture. The model developed offers the advantage of

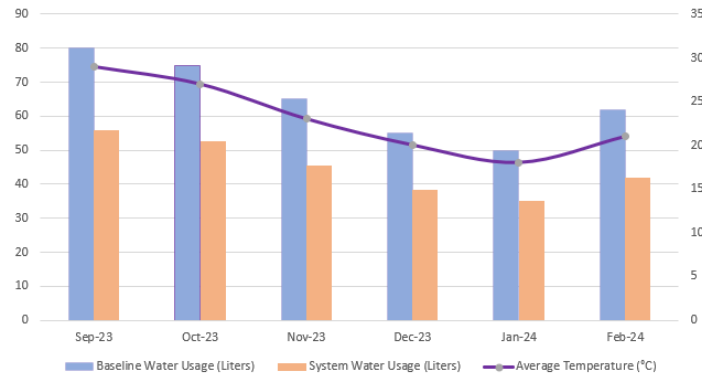

Figure 15. Comparison of water usage by Baseline and through automated system

being able to manage complex and non-linear data. Furthermore, the model also possesses the capability to provide accurate predictions and suggestions. Multiple linear regression permits for predicting crop production on the basis of environmental and soil conditions and is governed by the equation below,

$$p = \beta_0 + \beta_1 * Y_1 + \beta_2 * Y_2 + \beta_3 * Y_3 + \dots + \beta_n * Y_n + \varepsilon \quad (19)$$

Where  $p$  indicates productivity,  $y$  denotes the predictor variable,  $\beta$  is the slope of the regression line, and  $\varepsilon$  is random error. The authors also use a genetic algorithm, ant colony algorithm, and the Kriging algorithm because of their technical superiority to answer the obstacles of modern agriculture. An IoT-based drip irrigation system for the yield of mustard leaf is proposed by authors in [60]. The work detailed an effective monitoring system to study the change in soil and weather conditions. The weather station coupled with the IoT-based Arduino prototype was used to calculate the loss of water from plants due to evapotranspiration. The calculation for  $ET_0$  is made hourly and an estimation is done using the equation below,

$$ET_0 = \frac{0.408\Delta(R - H) + \beta \frac{900}{T+273} V_2(e_s - e_a)}{\Delta + \beta(1 + 0.34V_2)} \quad (20)$$

where,  $ET_0$  is the reference evapotranspiration.  $\Delta$  represents the slope vapor pressure curve.  $R$  is the net radiation at the solar surface.  $H$  is the soil heat flux density.  $T$  is the mean daily air temperature at 2 m height.  $V_2$  is the wind speed at 2 m height.  $e_s$  is the saturation vapor pressure.  $e_a$  is the actual vapor pressure.  $\beta$  is the psychrometric constant.

## 6. Future Works and Limitations

### 6.1. Future Works

It is necessary to understand the potentiality of integrating more sensors related to moisture, pH, and light. This larger context concerning advanced soil and environmental sustainability will be able to provide a reliable outcome in the future. Improvised machine learning and deep learning models can be implemented in this scenario to develop the maintenance. Some security measures should be taken into account for data transferring and sharing with other devices. In the future, a survey could be done regarding the end user response to the use of Gardino and the root level satisfaction of the users. In the future, the proposed model may be developed in a more convenient manner where the limitations will be solved.

Table 3. A brief comparison with other studies using different assessment parameters

Assessment parameters	[54]	[9]	[11]	[29]	[55]	[56]	Proposed system
Node MCU	yes	no	no	yes	no	no	yes
DHT11	no	yes	no	no	yes	no	yes
Galileo board	no	no	no	no	no	yes	no
5V Humidifier	no	yes	yes	no	no	no	yes
PIR sensor	no	no	no	no	no	no	yes

## 6.2. Limitations

Considering indoor and larger concepts for commercial purposes, this modular setup may cost a little bit more than the indoor irrigation system. Different types of devices are connected to this system. As a result, improper responses may hamper the whole system. Importantly, the sustainable proposed system is fully dependent on the Internet. As a consequence, if the internet is crushed, the entire communication may fall down. The other thing that is most concerning is the end user of this system will be the farmer, so there is an important role is to provide the knowledge to the farmers to establish the network and the use of automated devices. As a result, they can use the system for their irrigation in a larger way. As the farmers are not that educated, considering the use of automated systems connected with IoT and the Cloud will be a challenge for the provider, particularly in establishing a modular system of gardening. Data security is another part of this system that can be taken under consideration because the proposed model uses the cloud and another network to share data.

## 7. Conclusion

In this research, we investigate IoT-based automatic home gardens to improve resource efficiency and maintain healthy gardens. This innovation drastically lowers water and resource usage with regular upkeep and ongoing monitoring, encouraging sustainability and conservation. We highlight the value of proactive monitoring in tackling agricultural concerns by gathering and analyzing farm data. Our work strives to promote environmental conservation and enhance community life around the world by encouraging others to take on similar initiatives. An environmentally friendly approach for scalable sustainable practices is provided by IoT technology in gardening. IoT in agriculture has a bright future and can help create a greener world and better living conditions for future generations. Let's work together to make the earth more sustainable and healthier. To improve the overall smart gardening experience in the future, these improvements include improving mobile apps and physical components, implementing detailed parameter analysis, adding a security system for flower pots, plant growth monitoring, forecasting, temperature and humidity control, and email integration and SMS notifications. This system presents an indoor gardening system that can also be applicable for larger concerns based on IoT that aims to improve and optimize urban gardening techniques for recreational users. The proposed concept helps to build a modular garden with sustainability and scalability that ensures the optimized output of the gardening system using limited space and resources. Crucial environmental factors can be taken into account immediately with this system, which ensures smart gardening with lower cost and precious action. According to the proposed model considering which plant is sustainable for the weather conditions, the area of the surroundings will grow modern, more greener, healthier, and comfortable to living agents.

### **Acknowledgement:**

Thank all the people who contributed to this paper.



**Data Availability:**

Data will be made available on request.

**Declaration of Generative AI and AI-assisted Technologies in the Writing Process:**

During the preparation of this work the authors utilized Grammarly and ChatGPT in order to improve language and readability. After using this tool/service, the authors reviewed and edited the content as needed and took full responsibility for the publication's content.

**Declaration of Competing Interest:**

The authors declare that they have no competing interests.

## REFERENCES

1. A. Rahman, J. Islam, D. Kundu, R. Karim, Z. Rahman, S. S. Band, M. Sookhak, P. Tiwari, and N. Kumar, "Impacts of blockchain in software-defined internet of things ecosystem with network function virtualization for smart applications: Present perspectives and future directions," *International Journal of Communication Systems*, p. e5429, 2023.
2. R. Aarthi, D. Sivakumar, and V. Mariappan, "Smart soil property analysis using iot: A case study implementation in backyard gardening," *Procedia Computer Science*, vol. 218, pp. 2842–2851, 2023.
3. D. P. Rani, D. Suresh, P. R. Kapula, C. M. Akram, N. Hemalatha, and P. K. Soni, "Iot based smart solar energy monitoring systems," *Materials Today: Proceedings*, vol. 80, pp. 3540–3545, 2023.
4. C. Xu, X. Zhang, H. H. Yang, X. Wang, N. Pappas, D. Niyato, and T. Q. Quek, "Optimal status updates for minimizing age of correlated information in iot networks with energy harvesting sensors," *IEEE Transactions on Mobile Computing*, 2023.
5. M. S. I. Khan, A. Rahman, S. Islam, M. K. Nasir, S. S. Band, and A. Mosavi, "Iot and wireless sensor networking-based effluent treatment plant monitoring system," *Acta Polytechnica Hungarica*, vol. 18, no. 10, pp. 205–224, 2021.
6. A. Rahman, M. S. I. Khan, A. Montieri, M. J. Islam, M. R. Karim, M. Hasan, D. Kundu, M. K. Nasir, and A. Pescapè, "Blocksd-5gnet: Enhancing security of 5g network through blockchain-sdn with ml-based bandwidth prediction," *Transactions on Emerging Telecommunications Technologies*, vol. 35, no. 4, p. e4965, 2024.
7. M. R. Anggara and A. Disbuhadi, "a prototype design of smart quranic garden system using atmega328 and esp8266 microcontrollers," *Islamic Research*, vol. 5, no. 1, pp. 69–77, 2022.
8. M. Ali, N. Kanwal, A. Hussain, F. Samiullah, A. Iftikhar, and M. Qamar, "Iot based smart garden monitoring system using nodemcu microcontroller," *International Journal of Advances in Applied Sciences*, vol. 7, no. 8, pp. 117–124, 2020.
9. B. Min and S. J. Park, "A smart indoor gardening system using iot technology," in *Advances in Computer Science and Ubiquitous Computing: CSA-CUTE 17*. Springer, 2018, pp. 683–687.
10. M. D. D. bin Sadli *et al.*, "An iot-based smart garden with weather station system," in *2019 IEEE 9th Symposium on Computer Applications & Industrial Electronics (ISCAIE)*. IEEE, 2019, pp. 38–43.
11. D.-A. RADU and S.-V. OPREA, "Informatics solution for smart garden based on sensors," *Database Systems Journal BOARD*, p. 13.
12. M. I. Jaya, M. A. Amir, S. I. Hisham, A. Zabidi, and M. F. Ab Razak, "Sigma: A real-time soil and environment remote monitoring for indoor garden management."
13. M. M. Hossain, M. A. Rahman, S. Chaki, H. Ahmed, A. Haque, I. Tamanna, S. Lima, J. F. Most, and M. S. Rahman, "Smart-agri: A smart agricultural management with iot-ml-blockchain integrated framework," *International Journal of Advanced Computer Science and Applications*, vol. 14, no. 7, 2023.
14. X. Fernando and G. Lăzăroi, "Spectrum sensing, clustering algorithms, and energy-harvesting technology for cognitive-radio-based internet-of-things networks," *Sensors*, vol. 23, no. 18, p. 7792, 2023.
15. M. A. B. M. Yaziz, S. M. Uddin, and M. I. A. Bakar, "Development of iot on irrigation system for garden," *Journal of Engineering Technology*, vol. 10, no. 1, pp. 49–55, 2022.
16. S. Olawepo, A. Adebisi, M. Adebisi, and O. Okesola, "An overview of smart garden automation," in *2020 International Conference in Mathematics, Computer Engineering and Computer Science (ICMCECS)*. IEEE, 2020, pp. 1–6.
17. E. A. Abioye, M. S. Z. Abidin, M. S. A. Mahmud, S. Buyamin, O. D. Ijike, A. O. Otuoze, A. A. Afis, and O. M. Olajide, "A data-driven kalman filter-pid controller for fibrous capillary irrigation," *Smart Agricultural Technology*, vol. 3, p. 100085, 2023.
18. K. M. Hosny, A. Magdi, A. Salah, O. El-Komy, and N. A. Lashin, "Internet of things applications using raspberry-pi: a survey," *International Journal of Electrical & Computer Engineering (2088-8708)*, vol. 13, no. 1, 2023.
19. A. Rahman, K. Hasan, D. Kundu, M. J. Islam, T. Debnath, S. S. Band, and N. Kumar, "On the icn-iot with federated learning integration of communication: Concepts, security-privacy issues, applications, and future perspectives," *Future Generation Computer Systems*, vol. 138, pp. 61–88, 2023.
20. H. Sekkat, O. Moutik, L. Ourabah, B. ElKari, Y. Chaibi, and T. A. Tchakoucht, "Review of reinforcement learning for robotic grasping: Analysis and recommendations," *Statistics, Optimization & Information Computing*, vol. 12, no. 2, pp. 571–601, 2024.
21. A. Rahman, C. Chakraborty, A. Anwar, M. R. Karim, M. J. Islam, D. Kundu, Z. Rahman, and S. S. Band, "Sdn-iot empowered intelligent framework for industry 4.0 applications during covid-19 pandemic," *Cluster Computing*, pp. 1–18, 2021.

22. M. J. I. Tutul, M. Alam, and M. A. H. Wadud, "Smart food monitoring system based on iot and machine learning," in *2023 International Conference on Next-Generation Computing, IoT and Machine Learning (NCIM)*. IEEE, 2023, pp. 1–6.
23. M. Arefin, A. H. Wadud, A. Rahman, F. Islam, T. Hossain, T. Ehsan, and A. Halder, "An iot-based integrated solution for fire detection alarm system and water supply management," in *2023 International Conference on Information and Communication Technology for Sustainable Development (ICT4SD)*. IEEE, 2023, pp. 357–361.
24. M. Sheth and P. Rupani, "Smart gardening automation using iot with blynk app," in *2019 3rd international conference on trends in electronics and informatics (ICOEI)*. IEEE, 2019, pp. 266–270.
25. S. Sharma, A. Sharma, T. Goel, R. Deoli, and S. Mohan, "Smart home gardening management system: A cloud-based internet-of-things (iot) application in vanet," in *2020 11th International Conference on Computing, Communication and Networking Technologies (ICCCNT)*. IEEE, 2020, pp. 1–5.
26. F. Wang, Y.-m. Yang, X. Li, and O. Petrosian, "A modified inexact sarah algorithm with stabilized barzilai-borwein step-size in machine learning," *Statistics, Optimization & Information Computing*, vol. 12, no. 1, pp. 1–14, 2024.
27. S. N. Nobel, M. A. H. Wadud, A. Rahman, D. Kundu, A. A. Aishi, S. Sazzad, M. Rahman, M. A. Imran, O. F. Sifat, M. Sayduzzaman *et al.*, "Categorization of dehydrated food through hybrid deep transfer learning techniques," *Statistics, Optimization & Information Computing*, 2024.
28. O. Alshebly and S. N. Abdullah, "Proposed two-steps procedure of classification high dimensional data with regularized logistic regression," *Statistics, Optimization & Information Computing*, vol. 12, no. 2, pp. 325–342, 2024.
29. N. Abd Rahim, F. Zaki, and A. Noor, "Smart app for gardening monitoring system using iot technology," *system*, vol. 29, no. 04, pp. 7375–7384, 2020.
30. N. Sukhdev, N. Nahata, S. Sridhara, and G. Swamy, "Iot enabled smart gardening," in *2018 Fourteenth International Conference on Information Processing (ICINPRO)*. IEEE, 2018, pp. 1–2.
31. M. S. Mekala and P. Viswanathan, "A survey: Smart agriculture iot with cloud computing," in *2017 international conference on microelectronic devices, circuits and systems (ICMDCS)*. IEEE, 2017, pp. 1–7.
32. H.-H. Kim, M.-J. Kwak, K.-J. Kim, Y.-K. Gwak, J.-H. Lee, and H.-H. Yang, "Evaluation of iaq management using an iot-based indoor garden," *International Journal of Environmental Research and Public Health*, vol. 17, no. 6, p. 1867, 2020.
33. A. R. Yanes, P. Martinez, and R. Ahmad, "Towards automated aquaponics: A review on monitoring, iot, and smart systems," *Journal of Cleaner Production*, vol. 263, p. 121571, 2020.
34. H. Mohapatra, M. K. Dehury, A. Guru, and A. K. Rath, "Iot-enabled zero water wastage smart garden," in *IoT Enabled Computer-Aided Systems for Smart Buildings*. Springer, 2023, pp. 71–89.
35. D. Nethikumarage, L. Liyanage, S. Samarakoon, P. Ramkumar, S. Harshanath, and U. S. Rajapaksha, "Gardenpro-android mobile application for home garden management using machine learning augmented reality and iot," in *2022 IEEE 10th Region 10 Humanitarian Technology Conference (R10-HTC)*. IEEE, 2022, pp. 300–305.
36. S. T. Fauziah, E. Mulyana, A. I. Nur, S. Uyun, T. Yusuf, and R. Mardiyati, "Prototype of smart garden system for monitoring horticulture plants based on lora technology," in *2022 8th International Conference on Wireless and Telematics (ICWT)*. IEEE, 2022, pp. 1–5.
37. C. Ceccarini, K. Chan, I. L. Lok, R. Tse, S.-K. Tang, and C. Prandi, "Fostering user's awareness about indoor air quality through an iot-enabled home garden system," in *2021 International Conference on Computer Communications and Networks (ICCCN)*. IEEE, 2021, pp. 1–4.
38. C. Stoiljescu-Crisan, C. Crisan, and B.-P. Butunoi, "An iot-based smart home automation system," *Sensors*, vol. 21, no. 11, p. 3784, 2021.
39. D. Kurniawan, R. J. Putra, A. Bella, M. Ashar, and K. Dedes, "Smart garden with iot based real time communication using mqtt protocol," in *2021 7th international conference on electrical, electronics and information engineering (ICEEIE)*. IEEE, 2021, pp. 1–5.
40. A. Mohanty and S. Roy, "Smart plant monitoring system using blynk application," in *Advances in Smart Communication Technology and Information Processing: OPTRONIX 2020*. Springer, 2021, pp. 193–205.
41. L. M. S. Campoverde, M. Tropea, and F. De Rango, "An iot based smart irrigation management system using reinforcement learning modeled through a markov decision process," in *2021 IEEE/ACM 25th International Symposium on Distributed Simulation and Real Time Applications (DS-RT)*. IEEE, 2021, pp. 1–4.
42. V. K. Srithar, K. Vishal Vinod, S. Mona Sweata, M. Karthika Gurubarani, and K. Abirami, "A smart plant watering system for indoor plants with optimum time prediction for watering," in *Inventive Systems and Control: Proceedings of ICISC 2021*. Springer, 2021, pp. 461–477.
43. Z.-H. Yang and J.-F. Tian, "A new property of the wallis power function," *Proceedings of the American Mathematical Society*, 2024.
44. C. Maraveas, P. G. Asteris, K. G. Arvanitis, T. Bartzanas, and D. Loukatos, "Application of bio and nature-inspired algorithms in agricultural engineering," *Archives of Computational Methods in Engineering*, vol. 30, no. 3, pp. 1979–2012, 2023.
45. F. Xia, I. W. Rangelow, and K. Youcef-Toumi, "Afm imaging control and system integration," in *Active Probe Atomic Force Microscopy: A Practical Guide on Precision Instrumentation*. Springer, 2024, pp. 249–285.
46. S. Plancade, E. Marchadier, S. Huet, A. Ressayre, C. Noûs, and C. Dillmann, "A successive time-to-event model of phyllochron dynamics for hypothesis testing: application to the analysis of genetic and environmental effects in maize," *Plant Methods*, vol. 19, no. 1, p. 54, 2023.
47. T. Thamaraimeanalan, S. Vivekk, G. Satheshkumar, and P. Saravanan, "Smart garden monitoring system using iot," *Asian Journal of Applied Science and Technology (AJAST)*, vol. 2, no. 2, pp. 186–192, 2018.
48. A. Rahman, M. J. Islam, S. S. Band, G. Muhammad, K. Hasan, and P. Tiwari, "Towards a blockchain-sdn-based secure architecture for cloud computing in smart industrial iot," *Digital Communications and Networks*, vol. 9, no. 2, pp. 411–421, 2023.
49. P. Jariyayothin, K. Jeravong-Aram, N. Ratanachaijaroen, T. Tantidham, and P. Intakot, "Iot backyard: Smart watering control system," in *2018 Seventh ICT International Student Project Conference (ICT-ISPC)*. IEEE, 2018, pp. 1–6.
50. M. Bassiouni, S. Manzoni, and G. Vico, "Optimal plant water use strategies explain soil moisture variability," *Advances in Water Resources*, vol. 173, p. 104405, 2023.

51. A. Rahman, M. J. Islam, M. S. I. Khan, S. Kabir, A. I. Pritom, and M. R. Karim, "Block-sdotcloud: Enhancing security of cloud storage through blockchain-based sdn in iot network," in *2020 2nd International Conference on Sustainable Technologies for Industry 4.0 (STI)*. IEEE, 2020, pp. 1–6.
52. A. Rahman, M. A. H. Wadud, M. J. Islam, D. Kundu, T. A.-U.-H. Bhuiyan, G. Muhammad, and Z. Ali, "Internet of medical things and blockchain-enabled patient-centric agent through sdn for remote patient monitoring in 5g network," *Scientific Reports*, vol. 14, no. 1, p. 5297, 2024.
53. A. H. Abbas, M. M. Mohammed, G. M. Ahmed, E. A. Ahmed, and R. A. A. A. Seoud, "Smart watering system for gardens using wireless sensor networks," in *2014 International Conference on Engineering and Technology (ICET)*. IEEE, 2014, pp. 1–5.
54. H. Durani, M. Sheth, M. Vaghasia, and S. Kotech, "Smart automated home application using iot with blynk app," in *2018 Second international conference on inventive communication and computational technologies (ICICCT)*. IEEE, 2018, pp. 393–397.
55. T. Shivaprasad and J. Shetty, "Sentiment analysis of product reviews: A review," in *2017 International conference on inventive communication and computational technologies (ICICCT)*. IEEE, 2017, pp. 298–301.
56. V. Yadav, S. Borate, S. Devar, R. Gaikwad, and A. Gavali, "Smart home automation using virtue of iot," in *2017 2nd International Conference for Convergence in Technology (I2CT)*. IEEE, 2017, pp. 313–317.
57. T.-h. Kim, V. S. Solanki, H. J. Baraiya, A. Mitra, H. Shah, and S. Roy, "A smart, sensible agriculture system using the exponential moving average model," *Symmetry*, vol. 12, no. 3, p. 457, 2020.
58. N. K. Nawandar and V. R. Satpute, "Iot based low cost and intelligent module for smart irrigation system," *Computers and electronics in agriculture*, vol. 162, pp. 979–990, 2019.
59. J. M. Núñez, J. M. Corchado, D. M. Giraldo, S. R. González, and F. De la Prieta, "Recommendation system using bio-inspired algorithms for urban orchards," *Internet of Things*, p. 101173, 2024.
60. E. A. Abioye, M. S. Z. Abidin, M. S. A. Mahmud, S. Buyamin, M. K. I. AbdRahman, A. O. Otuoze, M. S. A. Ramli, and O. D. Ijike, "Iot-based monitoring and data-driven modelling of drip irrigation system for mustard leaf cultivation experiment," *Information Processing in Agriculture*, vol. 8, no. 2, pp. 270–283, 2021.